



# Compact Brewhouse

## BHM 250



- Single-step infusion mashing ▲
- Multi-step infusion mashing ▲
- Decoction mashing ▲

### High quality manufacturing process

- modern welding techniques: TIG welding, laser welded cooling/heating sections (pillow plates) on tank jacket and tank bottom, orbital welded pipes
- automated grinding and polishing of welds and inner surfaces
- completely made of stainless steel, only certified materials are used (option: TiN-coated stainless steel)

### Design

- two-vessel brewhouse (mash mixer-lauter tun and kettle-whirlpool combination)
- mounted on a stainless steel frame and completely piped and wired
- vessels equipped with thermal oil heated bottom and jacket and insulated (option - steam heating)
- integrated electric oil heater
- organized manifold system easy accessible from the front
- with installed CIP system

### Touch screen control panel

User friendly graphical interface is easy to understand and allows simple monitoring and control of the beer brewing process:

- pump speed control, mixer rotating control, temperature regulation (separate for side heating and bottom heating)
- setting of timers and alarms
- possibility of performing the multi-step mashing procedure
- display of actual and set values



# Compact Brewhouse BHM 250



- Single-step infusion mashing ▶
- Multi-step infusion mashing ▶
- Decoction mashing ▶

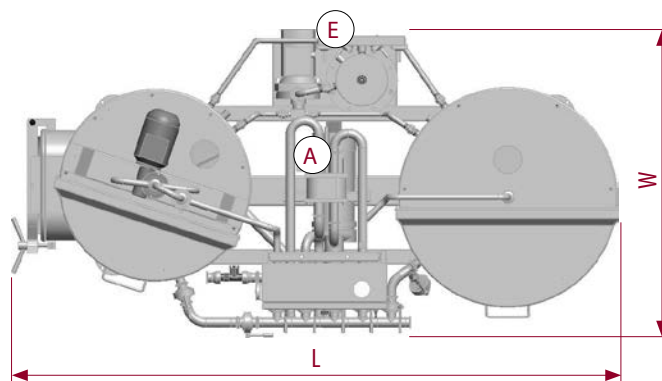
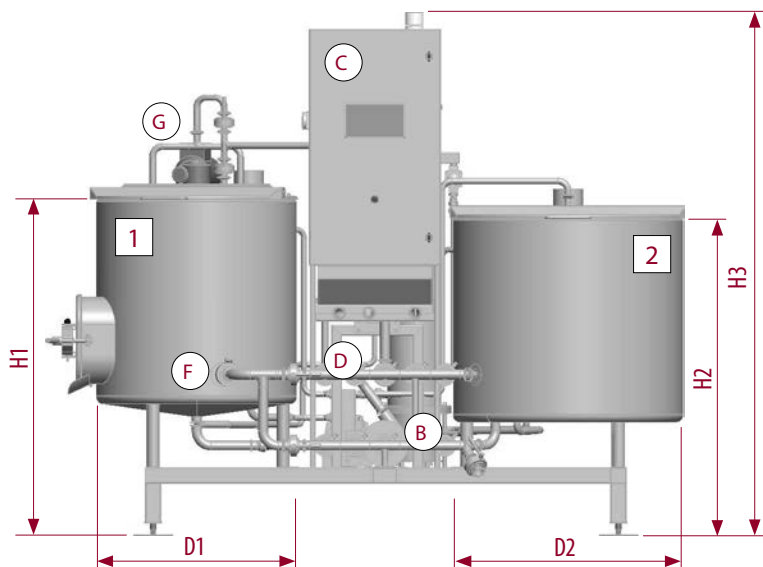

MM/LT volume (1)	L	265
K/W volume (2)	L	345
MM/LT diameter (D1)	mm	764
K/W diameter (D2)	mm	874
Height (H1)	mm	1285
Height (H2)	mm	1285
Total height (H3)	mm	1940
Total length (L)	mm	2380
Total width (W)	mm	1200
Electric power	kW	20

## Main components:

- 1** Mash mixer (MM) / Lauter tun (LT)
- 2** Kettle (K) / Whirlpool (W)
- A** Heat exchanger
- B** Pump
- C** Electric box with touch screen control panel
- D** Manifold with butterfly process valves
- E** Integrated oil heater with pump
- F** Inlet for decoction mashing
- G** Rake plow with motor (adjustable rotating speed)
- H** Wort filter before heat exchanger

\* Dimensions listed in the table are approximate and may vary slightly.

## Water tanks (optional):

Hot water tank WTX	600 L / 12 kW	1200 L / 18 kW	2000 L / 24 kW
Cold water tank CTX	600 L	1200 L	2000 L

